

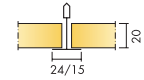

ECOPHON FOCUS™ A

For applications where a robust suspended ceiling system is required. Ecophon Focus A has an exposed grid system. Each tile is easily demountable.

The systems consist of Ecophon Focus A tiles and Ecophon Connect grid systems, with an approximate weight of 3 kg/m². The tiles are manufactured from high density glass wool. The visible surface has an Akutex™ FT coating and the back of the tile is covered with glass tissue. The edges are primed. The grid is manufactured from galvanized steel.



Focus A tile

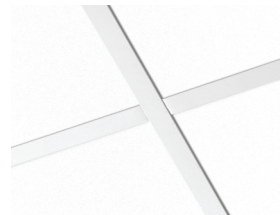
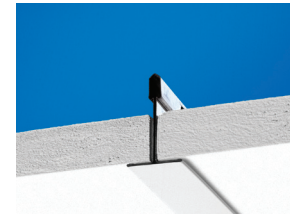

Focus A system

SYSTEM RANGE

Size, mm	Size, mm						
	600	1200	1200	1600	1800	2000	2400
	x	x	x	x	x	x	x
	600	600	1200	600	600	600	600
T15	•	•	•				
T24	•	•	•	•	•	•	•
Thickness	20	20	20	20	20	20	20
Inst. Diagr.	M01	M01	M01	M16, M46	M16, M46	M16, M46	M16, M46

TECHNICAL PROPERTIES

ACOUSTIC Sound Absorption Test results according to EN ISO 354. Classification according to EN ISO 11654, and the single value ratings for NRC and SAA according to ASTM C 423.

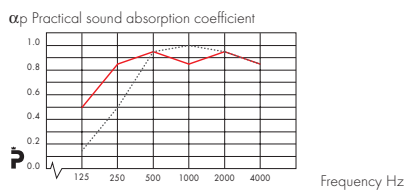

– Ecophon Focus A 200 mm o.d.s.
– Ecophon Focus A 50 mm o.d.s.
o.d.s = overall depth of system

Product	Focus A			
	50	80	200	400
o.d.s mm				
absorption class	B	A	A	
NRC	0.85	-	-	0.85
α_w				

Sound Insulation $D_{n,w}$ = 20 dB according to ISO 140-9 and evaluation according to EN ISO 717-1. CAC=21 dB according to ASTM E 1414 and evaluation according to ASTM E 413

Sound Privacy $AC(1.5)$ = 190 according to ASTM E 1111 and E 1110.

ACCESSIBILITY The tiles are easily demountable. Minimum demounting depth according to installation diagrams.

CLEANABILITY Daily dusting and vacuum cleaning. Weekly wet wiping.

VISUAL APPEARANCE White Frost, nearest NCS colour sample S 0500-N, 85% light reflectance (of which more than 99% is diffuse reflection). Retro reflection coefficient 63 mcd * m-2lx-1. Gloss < 1.

INFLUENCE OF CLIMATE The tiles withstand a permanent ambient RH up to 95% at 30°C without sagging, warping or delaminating (ISO 4611).

INDOOR CLIMATE Certified by the Indoor Climate Labelling, recommended by the Swedish Asthma and Allergy Association, and can be used in rooms classified as ISO class 6 according to ISO 14644-1.

ENVIRONMENTAL INFLUENCE Granted the Nordic Swan eco-label. Fully recyclable.

FIRE SAFETY The glass wool core of the tiles is tested and classified as non-combustible according to prEN ISO 1182. The systems are classified as fire protective covering according to NT FIRE 003. See Technical properties, Fire safety.

Reaction-to-fire classification

Country	Standard	Class
Europe	EN 13501-1	A2-s1,d0

MECHANICAL PROPERTIES For information regarding live load and requirements for load bearing capacity, see installation diagrams. Conditions: See Functional demands, Mechanical properties.

INSTALLATION Installed according to system range which includes information regarding minimum overall depth of system.

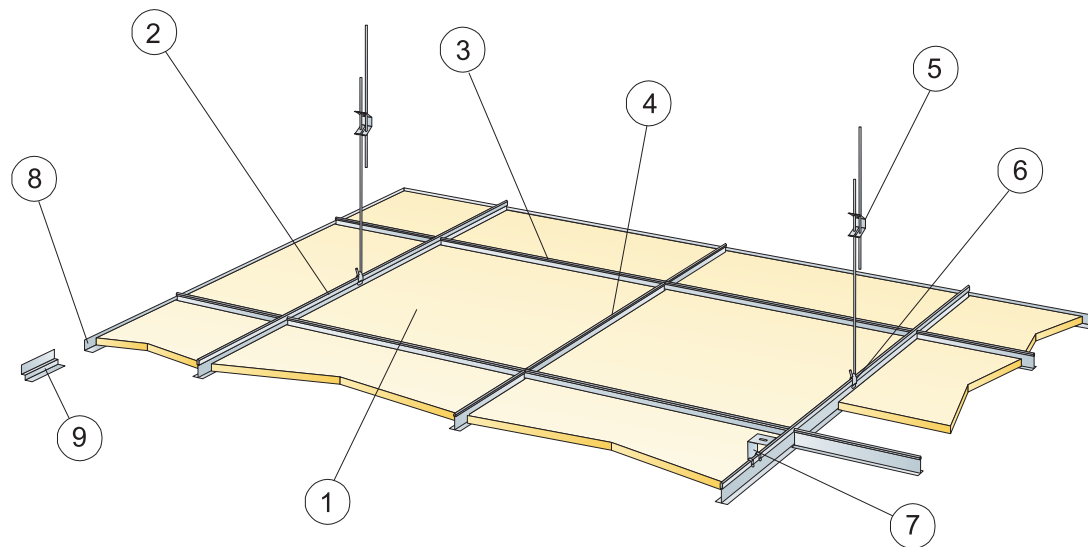

© Ecophon Group

QUANTITY SPECIFICATION (EXCL. WASTAGE)

	Size, mm		
	600x600	1200x600	1200x1200
1 Ecophon Focus A	2,8/m ²	1,4/m ²	0,7/m ²
2 Connect T24 or T15 Main runner, installed at 1200 mm centres	0,9m/m ²	0,9m/m ²	0,9m/m ²
3 Connect T24 or T15 Cross tee, L=1200 mm, installed at 600 mm centres	1,7m/m ²	1,7m/m ²	0,9m/m ²
4 Connect T24 or T15 Cross tee, L=600 mm	0,9m/m ²	-	-
5 Connect T24 Cross tee, L=1200 mm, installed at 600 mm centres	0,7/m ²	0,7/m ²	0,7/m ²
6 Connect Hanger clip	0,7/m ²	0,7/m ²	0,7/m ²
7 For direct installation: Connect Direct bracket, installed at 1200 mm centres	0,7/m ²	0,7/m ²	0,7/m ²
8 Connect Angle trim, fixed at 300 mm centres	as required	as required	as required
9 Connect Shadow-line trim, fixed at 300 mm centres	as required	as required	as required
Δ Min. overall depth of system, with Adjustable hanger: 100 mm, with Direct bracket: 50 mm	-	-	-
δ Min. demounting depth: 120 mm (130 mm with 1200x1200)	-	-	-

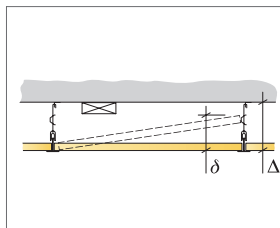

See Quantity specification

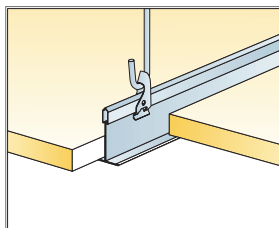

Suspension with adjustable hanger and clip

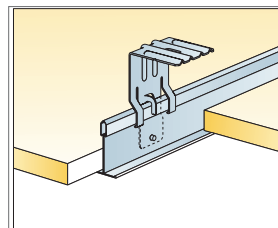

Suspension with direct bracket

Size, mm	Max live load [N]	Min load bearing capacity [N]
600x600	50	160
1200x600	50	160
1200x1200	50	160

Live load/load bearing capacity

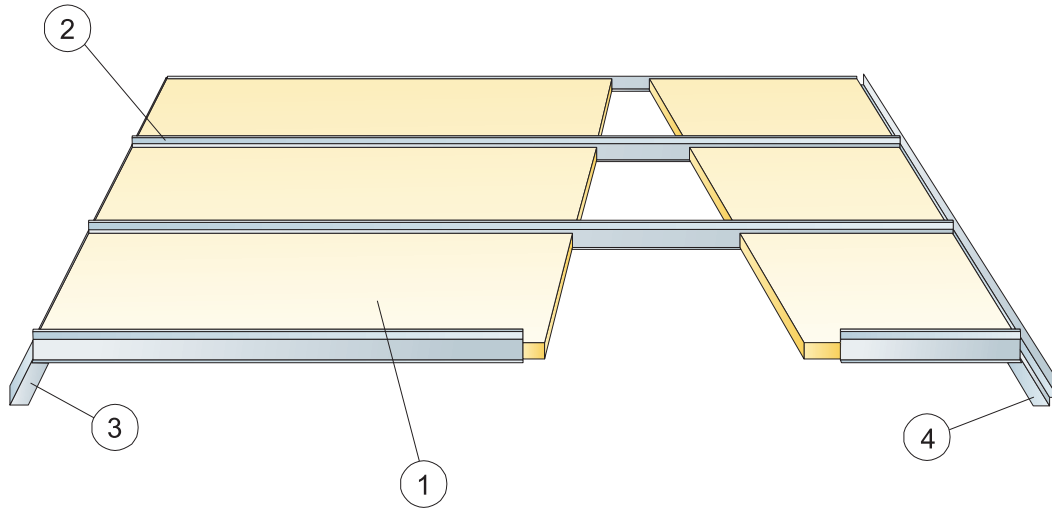

© Ecophon Group

QUANTITY SPECIFICATION (EXCL. WASTAGE)

		Size, mm			
		1600x600	1800x600	2000x600	2400x600
1	Focus A	1,05/m ²	0,95/m ²	0,85/m ²	0,7/m ²
2	Connect T24 Corridor profile, installed at 600 mm centres	1,05/m ²	0,95/m ²	0,85/m ²	0,7/m ²
3	Connect Angle trim, fixed at 200 mm centres	as required	as required	as required	as required
4	Connect Shadow-line trim, fixed at 200 mm centres	as required	as required	as required	as required
Δ Min. overall depth of system: 40 mm		-	-	-	-
δ Min. demounting depth: 65 mm		-	-	-	-

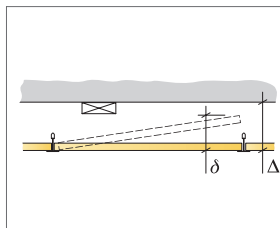

See Quantity specification

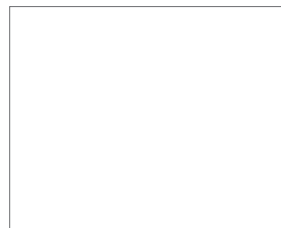
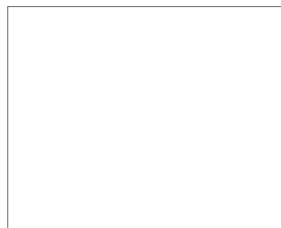

Size, mm	Max live load [N]	Min load bearing capacity [N]
1600x600	40	-
1800x600	20	-
2000x600	10	-
2400x600	0	-

Live load/load bearing capacity

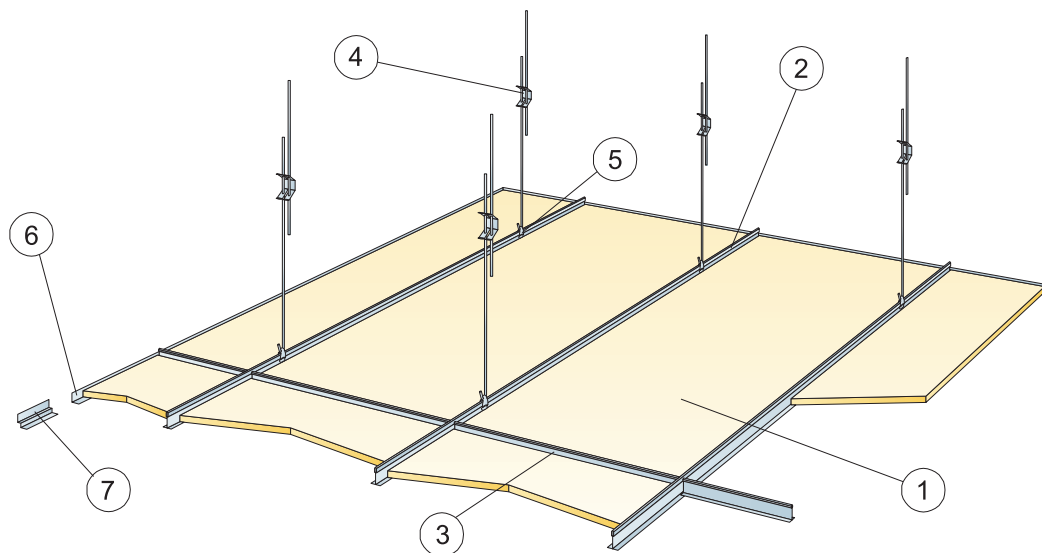

© Ecophon Group

QUANTITY SPECIFICATION (EXCL. WASTAGE)

		Size, mm			
		1600x600	1800x600	2000x600	2400x600
1	Focus A	1,05/m ²	0,95/m ²	0,85/m ²	0,7/m ²
2	Connect T24 Main runner, installed at 600 mm centres	1,7m/m ²	1,7m/m ²	1,7m/m ²	1,7m/m ²
3	Connect T24 Cross tee, l=600 mm	0,65m/m ²	0,6m/m ²	0,5m/m ²	0,45m/m ²
4	Connect Adjustable hanger, installed at 1500 mm centres (max. distance from wall 450 mm)	1,1/m ²	1,1/m ²	1,1/m ²	1,1/m ²
5	Connect Hanger clip	0,7/m ²	0,7/m ²	0,7/m ²	0,7/m ²
6	Connect Angle trim, fixed at 300 mm centres	as required	as required	as required	as required
7	Connect Shadow-line trim, fixed at 300 mm centres	as required	as required	as required	as required
Δ Min. overall depth of system: 100 mm		-	-	-	-
δ Min. demounting depth: 100 mm		-	-	-	-

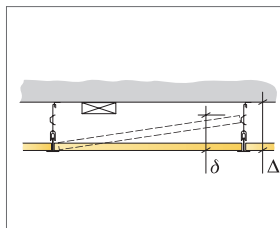

See Quantity specification

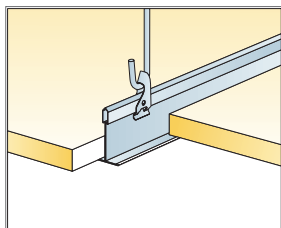

Suspension with adjustable hanger and clip

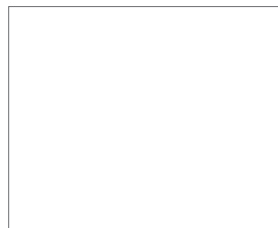

Size, mm	Max live load [N]	Min load bearing capacity [N]
1600x600	50	160
1800x600	50	160
2000x600	50	160
2400x600	50	160

Live load/load bearing capacity